

Paramount

Item#: PH-SQ201
Model#: LIP-10A-TGG

PATIO HEATER

INSTRUCTION MANUAL



WARNING: For outdoor use only.

NOTE: This heater has an Electronic Ignition and will require the installation of 1 - AAA battery. The battery should be installed by unscrewing the RED IGNITER BUTTON. The LED control box also requires the use of 8 - AA batteries. BATTERIES ARE NOT INCLUDED.

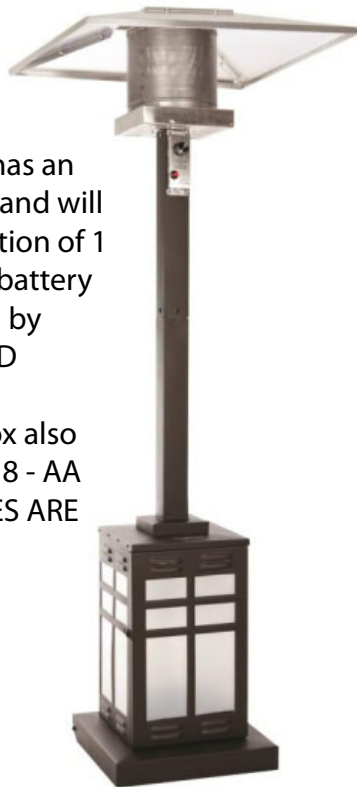

FOR YOUR SAFETY

If you smell gas:

1. Shut off gas to the appliance.
2. Extinguish any open flame.
3. If odor continues, immediately call gas supplier.

FOR YOUR SAFETY

Do not store or use gasoline or other flammable vapors or liquids in the vicinity of this or any other appliance.

For customer service, parts or warranty issues:

Call 1-800-561-5550

or e-mail customercare@jrhome.com

Establishing a burner ignition for the FIRST time or after changing the cylinder tank may take up to 2-3 minutes in order for the gas to purge through the feeder lines.

FOR OUTDOOR USE ONLY
PLEASE READ INSTRUCTIONS CAREFULLY BEFORE ASSEMBLY
RETAIN THIS MANUAL FOR REFERENCE

For customer service, parts
or warranty issues:
e-mail: customercare@jrhome.com

**** WARNING ****

Improper operation, installation, adjustment, alteration, servicing or maintenance cause severe property damage and /or serious damage and /or serious injury or death. Please read the installation, operating and maintenance instructions thoroughly before installing, operating or servicing this appliance.

**** For Your Safety ****

If you smell gas :

1. Shut off gas to appliance
2. Extinguish any open flame
3. If odour continues, immediately call your gas supplier

**** For Your Safety ****

Do NOT store or use gasoline or other flammable vapors in the vicinity of this or any other appliance.

Safety Information	—————	3
Security and caution	—————	4
Tools and accessories	—————	5
Assembly and instructions	—————	6~10
Operation	—————	11~13
Trouble shooting	—————	14
Storage and maintenance	—————	15



Establishing a burner ignition for the FIRST time or after changing the cylinder tank may take up to 2-3 minutes in order for the gas to purge through the feeder lines.

If stored indoors, detach and leave cylinder outdoors.

Keep this manual in your files for future reference.

NOTE : 20 lb., 5 Gallon LPG tank is not included

**** IMPORTANT NOTICE****

Do NOT return to place of purchase!!!
Please contact our Toll Free Hotline: 1-800-561-5550
for customer service and warranty issues
e-mail: customercare@jrhome.com
Hotline hours: Mon. to Fri. 7:00am - 4:00pm (P.S.T.)

This appliance is a propane portable heater.
The burner is controlled and adjusted by the gas control knob.
Gas supply is controlled by the valve on the gas cylinder.

The burner is made of stainless steel. Heat diffusion is assisted by the reflector.

Technical specification:

- Operating pressure : 11" W.C.
- Maximum input : 46,000 btu/h
- Minimum input : 26,500 btu/h
- Gas consumption at HIGH : 1 kg/h
- Approx. weight : 27 kg
- Burner orifice size : 2.2 mm

Gas Pressure	Main Orifice
Water Column	Diameter in mm
11" (2.75 Kpa)	2.2

MADE IN CHINA



** WARNING **

Improper operation, installation, adjustment, alteration, servicing or maintenance can cause severe property damage and/or serious damage and/or serious injury or death. Please read the installation, operating and maintenance instructions thoroughly before installing, operating or servicing this appliance.

FOR YOUR SAFETY

1. If you smell gas :
 - a. Close gas supply at cylinder valve
 - b. Extinguish all open flames
 - c. Proceed to perform a leak test with a soapy water solution (50% soap/ 50% water)
 - d. If bubbles are detected, retighten connections. If no leaks are detected, open gas valve at cylinder and verify if you smell gas.
 - e. If you still smell gas, shut-off heater completely and gas valve at cylinder or contact a gas appliance service center

2. Never store or handle gas, or any other flammable vapors or liquids in the vicinity of your Patio Heater or any gas appliance.

CAUTION

Faulty installation, modifications, repairs or maintenance to the appliance may cause injury or damage to property, and will void the warranty.

Carefully read this User Guide before assembling and setting up the heater.

Keep this guide for future reference.

CAUTION

- DO NOT operate the heater in an explosive environment. Keep this appliance away from areas where you have stored gas or other vapors and flammable liquids.
- Before use, verify that no parts are damaged, inspect gas hose.
- Never modify this appliance in any way or it will void the warranty.
- Never use the heater without the reflector shield.
- Respect minimum clearance from combustibles: top 36", sides 24".
- Always place heater on a leveled, stable and hard surface.
- Only use this heater outdoors.
- Never clean with abrasive, corrosive or flammable cleaners.
- Do not paint the heater or any of its parts.
- When fully assembled please perform a leak test, and every time you disconnect the hose, before lighting up the heater.
- A leak test must be performed before operating the appliance.
To perform a leak test, use a 50/50 mix of each water and soap in a spray bottle.
- NEVER LEAK TEST with an open flame or while smoking.
- The gas cylinder must be closed at all times when not using the heater.
- Children and adults should be made aware of hot surfaces on the heater.
- Clothing and other accessories or objects are not to be hung or laid on the heater or near it to dry.
- Do not obstruct the ventilation opening on cylinder cover.
- Installation, maintenance and repair of this heater should always be performed by a qualified gas technician.

PARTS LIST

- | | |
|-----------------------------------|----------------------------------|
| A. Reflector Panel and Center Cap | F. Post Support Plate |
| B. Head and Upper Post Assembly | G. Tank Housing Assembly |
| C. Gas Hose | H. Tank Housing Support Bar |
| D. Regulator | I. Tank Housing Door |
| E. Lower Post | J. LED Control Box
w/hardware |

Tools Required for Assembly (NOT included):

Phillips screwdriver w/medium blade

Leak Test Solution

Adjustable wrench (2) (Note: 10mm wrench or socket should fit M6 bolt;

13mm wrench or socket should fit M8bolt.)

NOTE: This heater has an Electronic Ignition and will require the installation of 1 - AAA battery. The battery should be installed by unscrewing the **RED IGNITER BUTTON**. The LED control box also requires the use of 8 - AA batteries. **BATTERIES ARE NOT INCLUDED.**

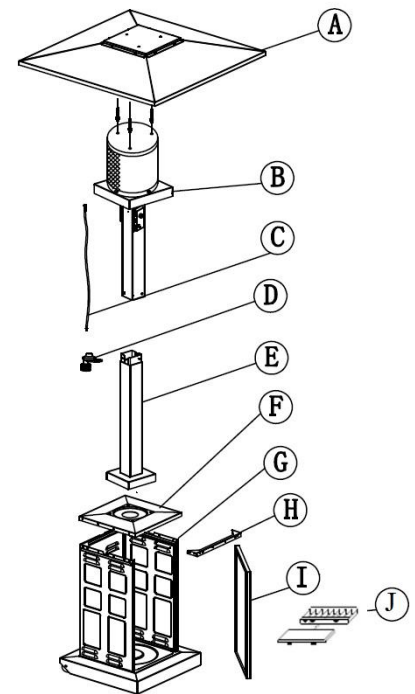

HARDWARE CONTENTS



1. Locate Tank Housing Assembly (G) and Tank Housing Support Bar (H). Attach Tank Housing Support Bar (H) to the top front edge of the Tank Housing Assembly (G) with 2 M4x10 (GG) Countersunk Head Screws (screws come pre-assembled in the Tank Housing Support Bar.)
Hardware Used: 2 x GG, Countersunk Head Screw M4x10

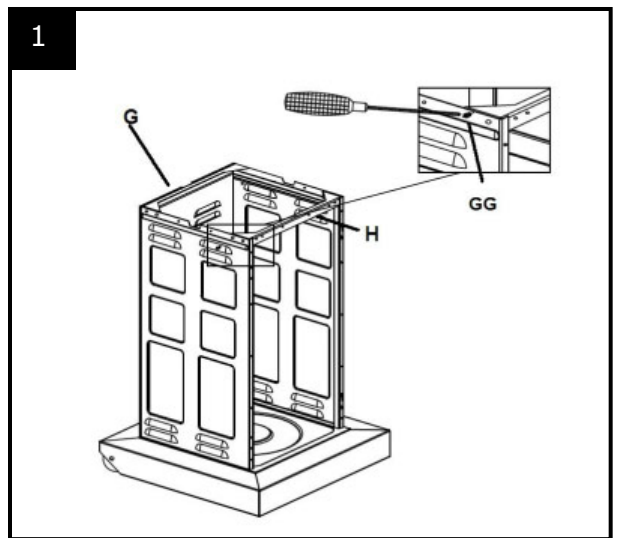

2. Attach the Lower Post (E) to the Post Support Plate (F) using 4 M8x16 (AA) Bolts and 4 M8 (FF) Washers.
(Note: Turn the post and support plate upside down to secure the bolts.)
Align the Post Support Plate (F) with the holes in the Lower Post (E), and insert 1 M8x16 (AA) Bolt through 1 M8 (FF) Washer and through the

Hardware Used: 4 x AA, Bolt M8x16
4 x FF, Washer M8

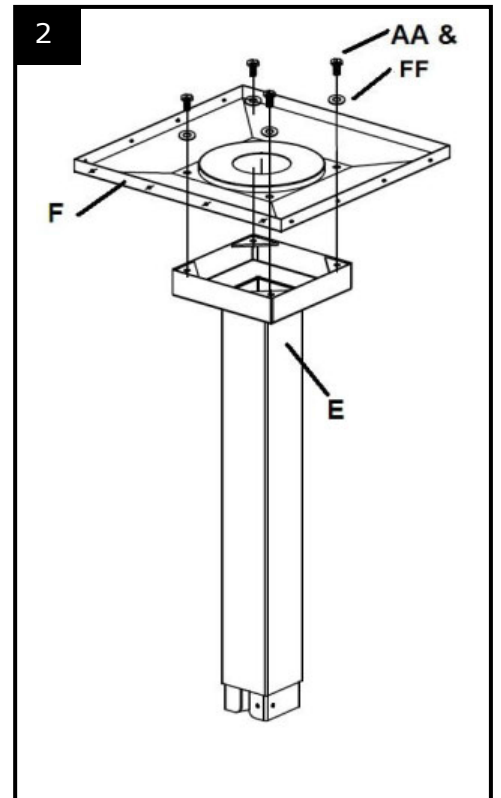

3. Attach the Post Support Plate (F)/Lower Post (E) to the Tank Housing Assembly (G/H). **(NOTE: Make sure Paramount logo is facing forward directly over the Tank Housing Support Bar.)** Align the holes in the Post Support Plate (F) With the holes in the top of the Tank Housing Assembly (G/H) and insert a total of 12 M4x10 (CC)bolts into the holes and loosely tighten. Once all bolts have been inserted, tighten with a wrench. Make sure you start from the back of tank housing.

Hardware Used: 12 x CC, Bolt M4x10

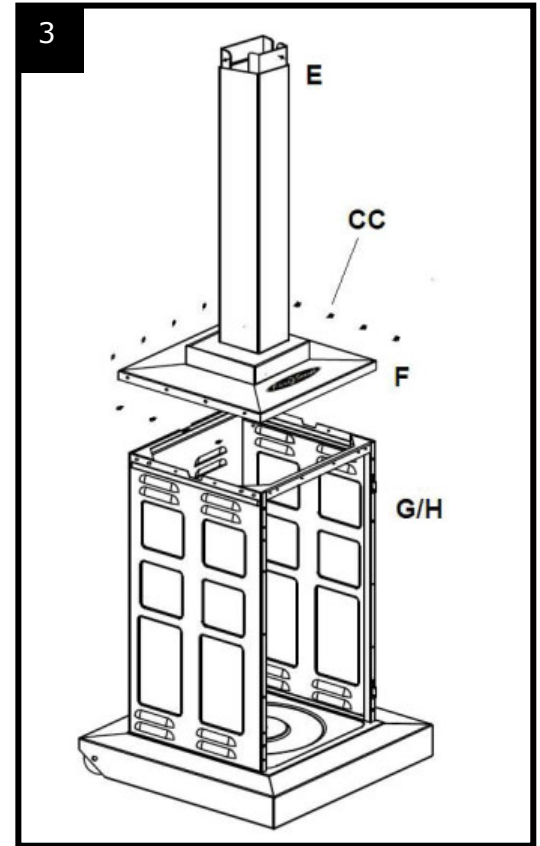

4. Attach Tank Housing Door (I) to the Tank Housing Assembly (G) by sliding the pins on the side of the door into the hinges located on the right side of the Tank Housing Assembly (G). **(NOTE: Make sure you hold door to the SIDE of the Tank Housing Assembly before trying to align pins. If you hold door to the FRONT of the Tank Housing Assembly, you will NOT be able to align pins correctly.)**

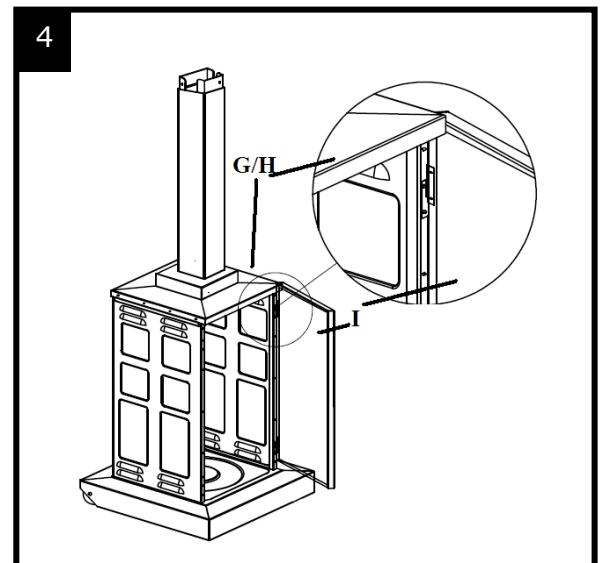

5. Carefully route the Gas Hose (C) that comes attached to Head and Upper Post Assembly (B) completely through the Lower Post/Post Support Plate Assembly (E/F).

(Hint: Control knob on Head Assembly should be located over the Tank Housing Door.)

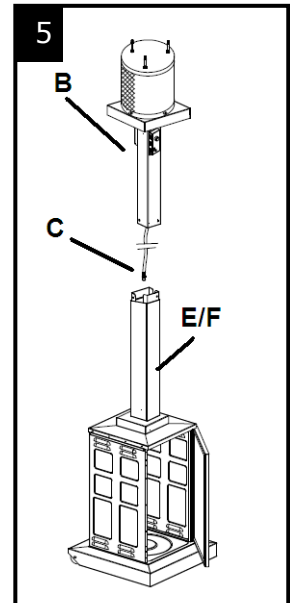

6. Attach Head Assembly and Upper Post Assembly (B) to the Lower Post (E) by aligning the 4 small holes located on the Upper Post with the 4 small holes located on the Lower Post (E). Insert 4 M6x12 (EE) bolts through 4 M6 lock washers and into holes and tighten with a wrench.

Hardware Used : 4 x EE, Bolt M6x12 and Lock Washer M6

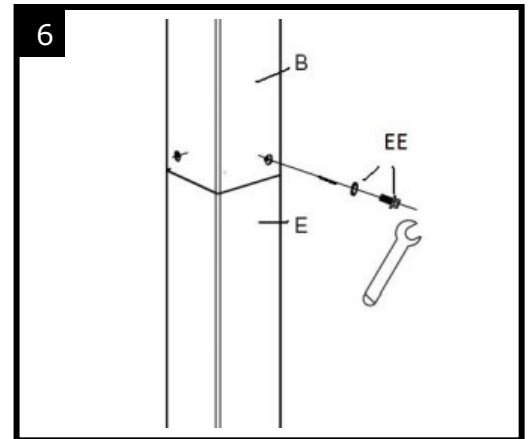

7. Assemble Reflector Panels and Center Cap (A). Reflector Panels and Center Cap (A) come packaged in two brown boxes with two panels in each box. Hardware for assembly is already affixed to each panel. Place two panels side by side and remove the two cap nuts and washers that are affixed to one panel. Insert the affixed bolts into the open holes on the adjacent panel. Place the washer over the bolt and screw on cap nut. Repeat these steps until all four panels are assembled. Then locate the Center Cap. You will need to remove the cap nuts and washers located at the top of each Reflector Panel to allow assembly of the Center Cap on each panel. Align the holes in the Center Cap with the bolts on each panel and affix washer and cap nut to complete assembly. **(Note : It is easiest to assemble reflector panels if you turn panels upside down. Once 4 panels are assembled, turn reflector right side up and then attach the cap.)**

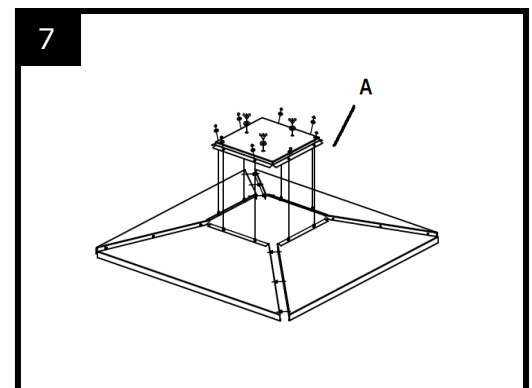

8. While supporting heater, tilt the Head and Upper Post Assembly (B) and screw in the 3 M8x66 Stud Bolts (BB) into the holes on top of the Head Assembly. Slide the assembled Reflector over the 3 bolts that now extend from the Head Assembly. Use the 3 M8 Wing Nuts (DD) and 3 M8 Washers (FF) to secure the assembled Reflector to the Head Assembly of the heater. Once you have tightened the Wing Nuts, return the heater to an upright position.

Hardware Used : 3 x BB, Stud Bolt with Nut
 3 x DD, Wing Nut M8
 3 x FF, Washer M8

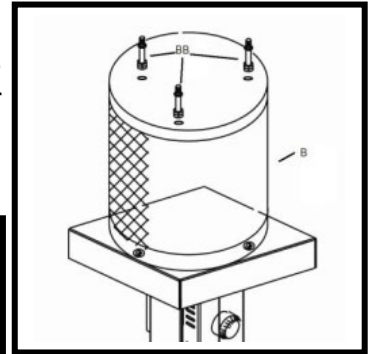
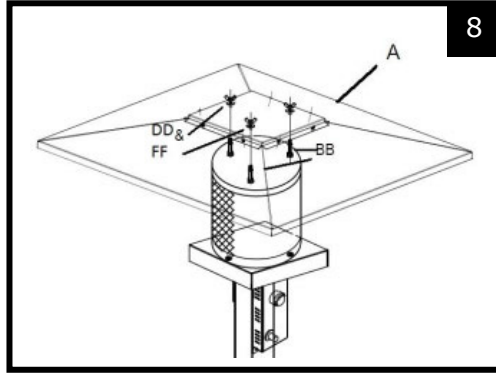
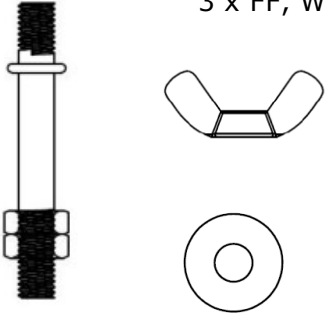

9. Connecting the LED feature:

This heater comes equipped with LED rope lights preassembled in the base and Post support plate (See Fig.1 and 2 below):

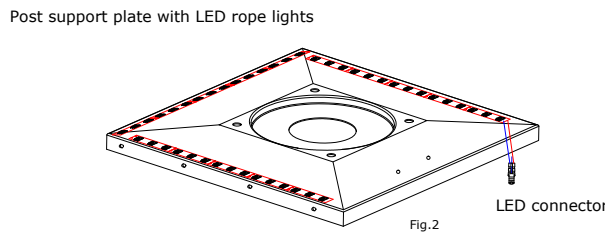
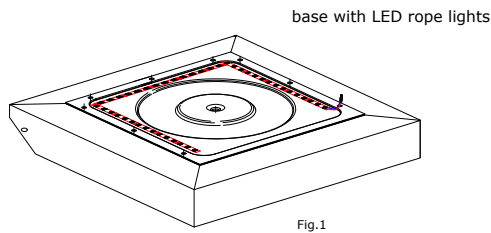

[NOTE: Before attaching the LED connectors to the LED control box, you must insert 8 - AA batteries (NOT included) by sliding the top of the LED control box off to release the top. Once the top is removed, insert the batteries and then replace the top by sliding it back down on the box.] Connect both sets of connectors and control LED feature with On/Off switch located on LED control box.

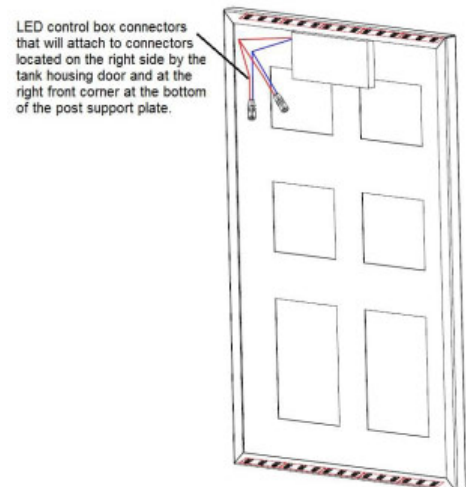
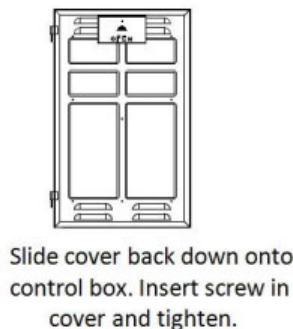
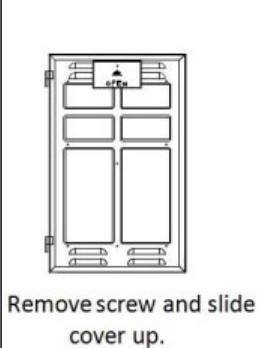

10. Connect the hose and regulator to the LP cylinder. The LP cylinder is sold separately. Use a standard 20 lb. propane cylinder only. Screw Regulator (D) onto Gas Hose (C). Do not cross thread. Hand tighten securely. Attach Regulator (D) to valve on LP cylinder and hand tighten securely. Place LP tank onto base of heater and close Tank Housing Door (I).

NOTE: Use this heater only with a propane vapor withdrawal supply system. See chapter 5 of the standard for storage and handling of liquefied petroleum gas, ANSI/NFPA 58. Your local library or fire department should have this book.

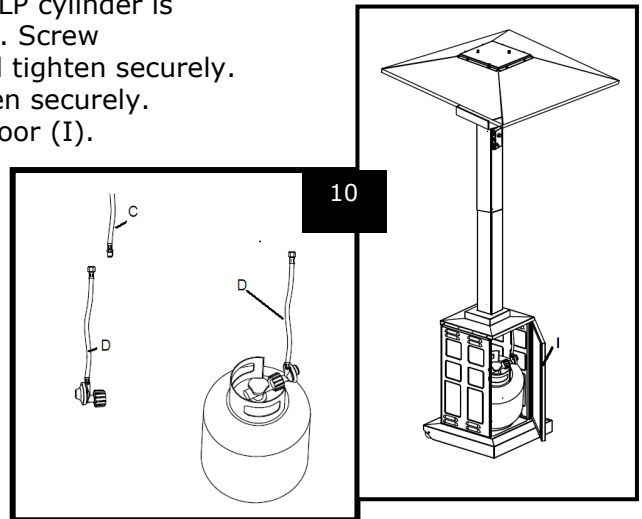

LEAK TEST

Now that the heater is assembled, for your safety you must perform a leak test of all connections and hoses.

Mix in a spray bottle equal parts of water and soap.

1. Ensure that the heater gas control knob is fully closed by turning completely clockwise
2. Open cylinder valve.
3. Apply generously the solution to all connections and hoses.

If you detect bubbles, there is a leak. Close cylinder valve completely. Retighten the leaking connection and repeat leak test process.

If the leak cannot be repaired permanently, close cylinder valve completely and contact the customer care department at customer care@jrhome.com or a qualified gas technician.

A SAFE LOCATION FOR THE HEATER

CAUTION

When objects are left under a heater in operation, they will be subject to radiant heat and might be damaged.

This heater is approved for outdoor use only.

- Provide fresh air ventilation at all times
- Respect minimum clearances to combustibles 36" top, 24" side.
- Install heater on a level, solid and stable ground.
- Do not install in an explosive environment. Keep away from areas from where gas, vapors or flammable liquids are stored or used.
- In case of high winds, completely shut-off the heater and the cylinder gas valve.
- Remove reflector dome.
- Do not move the heater when hot.

TO LIGHT

NOTE: For initial start or after any cylinder change, hold the control knob in for 2 minutes to purge air from all gas lines before proceeding. **NOTE:** This heater has an Electronic Ignition and will require installation of 1 - AAA battery. The battery should be installed by unscrewing the RED IGNITER BUTTON.

1. Turn the control knob to the "OFF" position.
2. Fully open the LP cylinder valve.
3. Turn the control knob counterclockwise to small flame symbol (MIN).
4. Push control knob in and then push the RED igniter button to ignite the main burner. Repeat until the burner ignites. Keep the control knob fully pushed in for an additional 10-20 seconds after the burner ignites, then release the control knob.
5. To increase the flame, turn the control knob clockwise toward the large flame symbol (MAX). To decrease the flame, turn the control knob counterclockwise towards the small flame symbol (MIN).
6. To turn the appliance OFF, turn the control knob clockwise to the OFF position.
7. Wait at least 5 minutes before attempting to re-light the heater.
8. Turn the gas cylinder valve to OFF or closed.

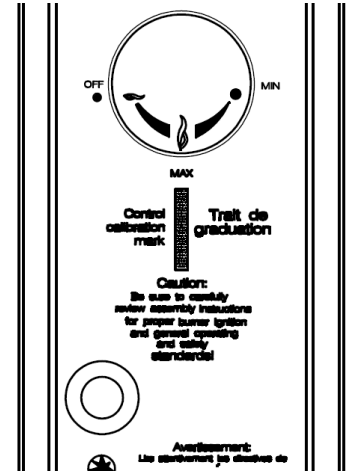

If you experience any ignition problems, please consult "Troubleshooting" on page 14.

Caution: Avoid inhaling fumes emitted from the heater's first use. Smoke and odor from the burning of oils used in the manufacturing will appear. Both smoke and odor will dissipate after approximately 30 minutes. The heater should NOT produce thick black smoke.

Re-Lighting:

Note: For your safety, control knob cannot be turned OFF without first depressing the control knob and then rotating to OFF.

1. Turn control knob to OFF.
2. Wait at least 5 minutes to allow gas to dissipate before re-lighting.
3. Repeat the "Lighting" steps listed above.

Shut Down:

1. Turn control knob clockwise to OFF while depressing the knob.
(Normally, burner will make a slight popping noise when extinguished).
2. Turn cylinder valve clockwise to OFF and disconnect regulator when heater is not in use.

NOTE: After use, some discoloration of the emitter screen is normal.

STORAGE

When heater is not in use for a prolonged period of time, remove gas cylinder. Verify that the gas valve is closed tightly.

Do not store the gas cylinder indoors.
Store gas cylinder in a well ventilated area.

PREVENTIVE CARE AND MAINTENANCE

Once a year, the heater should be inspected for debris, insects, or spider webs that could obstruct the burner. The burner area is likely to attract spiders. This may damage the burner if it is not kept clean of debris.

HAVE HEATER INSPECTED IF

- You smell gas combined with yellow tipped flames on burner.
- Heater does not provide expected heat capacity.
- Burner makes little explosion sounds while operating.
This sound is normal when turning off the heater.

PRECAUTIONS

- Verify periodically for leaks in the system, or immediately when you smell gas.
- In case a leak is detected, put out all open flame in the area.
- Never leak test while smoking.
- If you cannot repair a leak, turn off gas supply at the cylinder valve and contact a qualified technician.
- Do not alter or modify in any way.
- The installation of this appliance should be done by a certified gas technician in accordance with all local, building and municipal codes.

WARNING

FOR YOUR SAFETY

Be careful when attempting to manually ignite this heater. Holding in the control knob for more than 10 seconds before igniting the gas may cause a ball of flame upon ignition.

When heater is ON:

Emitter screen will become bright red due to intense heat. The color is more visible at night. Burner will display tongues of blue and yellow flame. These flames should not be yellow or produce thick black smoke, indicating an obstruction of airflow through the burners. The flame should be blue with straight yellow tops. If excessive yellow flame is detected, turn off heater and consult "Troubleshooting" on page 14.

WARNING

FOR YOUR SAFETY

Heater will be hot after use. Handle with extreme care.

Operation Checklist:

For a safe and pleasurable heating experience, perform this check before each use:

Before Operating:

1. I am familiar with entire owner's manual and understand all precautions noted.
2. All components are properly assembled, intact and operable.
3. No alterations have been made.
4. All gas connections are secure and do not leak.
5. Wind velocity is below 10 mph.
6. Unit will operate at reduced efficiency below 40 degrees F.
7. Heater is for use outdoors (outside any enclosure).
8. There is adequate fresh air ventilation.
9. Heater is away from gasoline or other flammable liquids or vapors.
10. Heater is away from windows, air intake openings, sprinklers and other water sources.
11. Heater is at least 36 in. on top and at least 24 in. on sides from combustible materials.
12. Heater is on a hard and level surface.
13. There are no signs of spider or insect nests in heater orifices.
14. All burner passages are clear.
15. All air circulation passages are clear.
16. Children and adults should be alerted to the hazards of high surface temperatures and should stay away to avoid burns or clothing ignition.
17. Young children should be carefully supervised when they are in the area of the heater.
18. Clothing or other protective material should not be hung from the heater, or placed on or near the heater.
19. Any guard or other protective device removed for servicing the heater must be replaced prior to operating the heater.
20. Installation and repair should be done by a qualified service person. The heater should be inspected before each use and at least annually by a qualified service person.
21. More frequent cleaning may be required as necessary. It is imperative that control compartment burner and circulating air passageways of the heater be kept clean and free of debris and/or spider or insect nests.

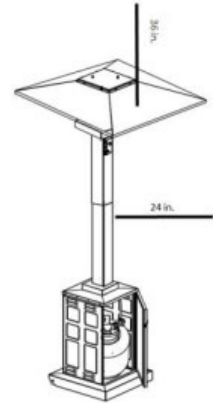

After Operation:

1. Gas control knob is in OFF position.
2. Gas tank valve is OFF.
3. Disconnect gas line.

TROUBLE SHOOTING GUIDE

If you are having this problem	If this condition exists:	You will need to do the following:
 <p>Burner flame will not stay on</p>	<ol style="list-style-type: none"> 1. Cylinder valve may be OFF. 2. LPG tank empty 3. Orifice blocked 4. Loose connection 5. Thermocouple failed 6. Gas leak in line 7. Lack of fuel pressure 8. AAA Battery behind igniterbutton is dead 	<ul style="list-style-type: none"> ▶ Open valve at cylinder. Turn cylinder valve in counter-clockwise direction. ▶ Refill LPG tank ▶ Clean Spider web or other blockage, or replace orifice. ▶ Check all fittings ▶ Replace thermocouple ▶ Turn tank off. Wait 5 minutes. Check fuel line connections. Reinsert regulator tighten firmly and re-try. ▶ Refill fuel tank ▶ Replace with a new AAA Battery
<p>Burner flame will not light</p>	<ol style="list-style-type: none"> 1. Pressure is low 2. Control not ON 3. Orifice blocked 	<ul style="list-style-type: none"> ▶ Tank is near empty ▶ Turn valve to ON and push in. ▶ Remove and clean out.
<p>Igniter does not work</p>	<p>Electrode might have accumulated black soot</p>	<ul style="list-style-type: none"> ▶ Light the burner manually or clean the electrode, check wire connections and re-try.
<p>LED lights will not come on</p>	<p>Dead battery</p>	<ul style="list-style-type: none"> ▶ Replace the AA batteries located in the LED control box

**** IMPORTANT NOTICE****

Do NOT return to place of purchase!!!
Please contact our Toll Free Hotline: 1-800-561-5550
for customer service and warranty issues
e-mail: customercare@jrhome.com
Hotline hours: Mon. to Fri. 7:00am - 4:00pm (P.S.T.)

CUSTOMER SERVICE

ATTENTION :

Consumer ... Please use the customer information listed below for any questions concerning assembly, care information, warranty issues and/or replacement parts.

To ensure your satisfaction and maintain high standards for quality and workmanship, we want to hear from you should you have any questions or comments. You can contact : J&R Home Products at 1-800-561-5550 7am to 4pm Pacific Standard Time Monday thru Friday or by e-mail: customercare@jrhome.com

Again, thank you for selecting our product line!

STORAGE & MAINTENANCE

STORAGE :

During the season :

- Control knob must be in OFF position
- Propane cylinder valve must be closed completely
- Patio heater must be upright and sheltered from any harsh weather conditions (i.e. strong winds, rain, heavy mist, snow, dust & debris)

During off season :

- Control knob must be in OFF position
- Disconnect LPG cylinder and store in a well ventilated OUTDOOR area where the temperature will not exceed 125 degrees F.
- Appliance should be upright and sheltered from outside weather conditions (i.e. rain, snow, hail, winds, dust, debris).
- It is recommended that the "head components" be wrapped or covered to protect against debris, dust and insects clogging air and gas passageways. Suggestion : use a poly trash can liner or polytarp material.

MAINTENANCE :

- Outside metal surface – Clean with warm soapy water and soft rags or paper towels. Do NOT use abrasive or corrosive cleaning agents. Be careful NOT to wet the burner or pilot ignition assemblies. Do NOT spray water or cleaning agents directly onto head components as severe damage may result.
- The aluminum reflector hood MUST be cleaned frequently. Do NOT allow carbon deposits to build. This will cause a significant fire hazard. Use warm soapy water or a non-abrasive solution and soft rags or paper towels.
- Obstruction of airflow & gas passageways is the primary cause of problems. Check burner assembly, ventila screen, control panel and intake lines before every use. Clean orifices and small vents with a pipe clean
A can of compressed air is very effective for cleaning out small particles, insects, and spiders.

Possible signs of obstructed air and gas passageways :

1. Heat glow on head component is very UNEVEN
2. Smell of gas and extreme yellow tipping of flame
3. Heating output (BTU) is noticeably reduced
4. Crackling or popping noises coming from heating components

NOTE : Locations near the ocean or saltwater will require more maintenance and frequent checking of components.

IMPORTANT

For questions, concerns or problems with our product please email our customer service department:

customercare@jrhome.com

DATED PROOF OF PURCHASE REQUIRED FOR WARRANTY SERVICE

Si vous éprouvez des difficultés ou si vous avez des questions ou des préoccupations, prière de faire parvenir un courriel à notre service à la clientèle

customercare@jrhome.com

UNE PREUVE D'ACHAT DATÉE EST REQUISE POUR SE PRÉVALOIR DE LA GARANTIE.

WARRANTY

This product is inspected, tested and carefully packaged to minimize the chance of damage during shipment. If a part (excluding light bulbs, glass and fuses*) within one year from the date of purchase proves to be defective in material or fabrication under normal use, the part will be repaired or replaced. The Company's obligation under the warranty is to replace or repair defective parts at our discretion. Any expenses or damage resulting from the installation, removal or transportation of the product will be the responsibility of the owner and are not covered by this warranty. The owner assumes all other risks arising from the use or misuse of the product. The warranty will be void if the product damage or failure is deemed by the Company to be caused by accident, alteration, misuse, abuse, incorrect installation or removal, or connection to an incorrect power source by the owner. The Company neither assumes, nor authorizes any person or entity to assume for it any obligation or liability associated with its products. Light bulbs and fuses are not covered under this warranty. If you have any questions regarding the warranty or service, please contact us at **customercare@jrhome.com**.

Customer Service :
JR Home Products
Unit 306 - 19100 Airport Way, Pitt Meadows, BC V3Y 0E2
Toll Free : 1-800-561-5550
E-mail : **customercare@jrhome.com**

AVERTISSEMENT

Ce produit a été soigneusement inspecté, testé et emballé afin de minimiser les risques de dommages durant le transport. Si l'une des pièces (à l'exception des verres, des ampoules électriques et des fusibles*) s'avère défectueuse au niveau de sa fabrication ou de ses matériaux dans l'année qui suit la date de l'achat suite à une utilisation normale, la pièce sera réparée ou remplacée. La compagnie est tenue de réparer ou remplacer les pièces défectueuses à sa discrétion, en vertu de la garantie. Tous frais ou dommage résultant de l'installation, du démantèlement ou du transport du produit demeurent la responsabilité du client et n'est pas couvert par cette garantie. Le client assume tout autre risque résultant de l'utilisation correcte ou fautive du produit. La garantie devient nulle si la compagnie détermine que le dommage ou le mauvais fonctionnement est causé par un accident, une modification, une mauvaise utilisation, un abus, une mauvaise installation ou un mauvais démantèlement ou un branchement à une source électrique inadéquate de la part du client. La compagnie n'est pas responsable et n'autorise quiconque, personne ou entité légale, à accepter de responsabilité ou obligation en son nom, en rapport avec ses produits. * Les ampoules électriques et les fusibles ne sont pas couverts par cette garantie. Pour toute question au sujet de la garantie ou du service, contacter le service à la clientèle à : **customercare@jrhome.com**.

Service à la clientèle:
JR Home Products
Unit 306 - 19100 Airport Way, Pitt Meadows BC V3Y 0E2 Numéro sans frais: 1-800-561-5550
Courriel: **customercare@jrhome.com**

You MUST register your product within 30 days of purchase to receive warranty service.

Registration can be completed online at www.jrhome.com or by mailing this form.

Vous DEVEZ enregistrer votre produit dans les 30 jours suivant l'achat pour bénéficier du service de garantie.

L'enregistrement sera complet une fois que vous aurez posté ce formulaire ou que vous serez inscrit en ligne.

Warranty Registration Information Form / Formulaire d'enregistrement de la garantie

Name / Nom : _____

Street / Adresse : _____

City / Ville : _____

Province / Province : _____

Postal Code / Code postal : _____

Daytime Phone # / No téléphone jour : _____

Evening Phone # / No téléphone soir : _____

E-Mail Address / Courriel : _____

Product/Produit : _____

Place of Purchase / Lieu de l'achat : _____

Date of Purchase / Date de l'achat : _____

Model # / No de modèle : _____

Serial # / Numéro de série : _____

You MUST register your product to receive warranty service.

For warranty service, contact J&R Home Products at the address, phone numbers listed below within 30 days of purchase. Be sure to have your sales receipt and original date of purchase. All warranty service will be coordinated by J&R Home Products service center.

Vous DEVEZ enregistrer votre produit pour vous prévaloir de la garantie.

Afin de faire valoir la garantie, communiquez avec J&R Home Products à l'adresse et aux numéros indiqués ci-dessous dans les 30 jours suivant la date d'achat. Ayez en main votre reçu et la date d'achat. Toutes les demandes liées aux garanties seront traitées par le centre de service de J&R Home Products.